



CITY OF BURNET
ENGINEERING AND PUBLIC WORKS

ADDENDUM NO. 1

April 6, 2022

**Woodlands Street Paving – RFP 2021-004
PID: CIPTR-2022A**

Ladies/Gentlemen:

The City of Burnet issues this Addendum on the above captioned project. This Addendum details the changes and the respective bid document pages which were added and/or changed. Each bidder is required to acknowledge receipt of this Addendum, on the form included in the Addendum below. Failure to acknowledge receipt of this Addendum in your bid proposal will result in your bid not being read.

Please sign and **return** this Addendum with your sealed bid packet at time and location as advertised on the Invitation to Bid for this project. Addendum should be located at the beginning of the packet. Failure to acknowledge all the addenda issued will result in bid dismissal.

DESIGN ENGINEER APPROVAL:

Eric Belaj, PE, CFM
City Engineer

Addendum items and pertaining attachment will be included in the following pages.

ADDENDUM BIDDER ACKNOWLEDGMENT BELOW OR BID DOCS (IF PROVIDED):

(Company Name)

(Bidder Rep. Name)

By: _____
(Signature)

Date: _____



CITY OF BURNET
ENGINEERING AND PUBLIC WORKS

1. **Bonds**: No Change
2. **Dates**: No Change
3. **Questions and Answers**: This Bid Addendum also answers questions posed by contractors throughout the bid process and at the pre-bid meeting as follows:
 - a. *Question from Bidder. See CivCast*
 - a. Answer.
4. **Bid Document Changes**: This item outlines changes to the Bid Documents:
 - a) This addendum revises the pavement thickness from 1.5” to 2” thick HMAC TYPE “D”

CONSTRUCTION COST FOR: **WOODLANDS STREET REHAB OVERLAY**

The *Pay Item* reference indicates the controlling specification for each Pay Item. Pay Item references are from the specifications referenced in *the Standard Form of Agreement*, unless otherwise noted.

Contractor responsible for the validity, format, and formulas in file.
PDF documents are official

PAY ITEM	DESCRIPTION	QUANTITY	UNIT	UNIT PRICE	EXTENDED PRICE
GENERAL CONDITIONS & PAVING					
1	MOBILIZATION, BONDS & INSURANCE	1	LS	\$ -	\$ -
2	REMOVE & DISPOSE OF TRAFFIC BUTTONS	1	LS	\$ -	\$ -
3	TRAFFIC CONTROL	1	LS	\$ -	\$ -
4	PAVEMENT 2" HMAC TYPE "D"	9,943	SY	\$ -	\$ -
5	JACKSON ST & HARVEY INTERSECTION (AVE 1.5" MILL AND TIE-IN)	125	SY	\$ -	\$ -
6	TIE-IN TO EXSITING CURB (REMOVE 1.5"x3' WIDE PVMT.)	3,530	LF	\$ -	\$ -
TOTAL BASE BID (TOTAL OF ITEMS IN THE COLUMNS ABOVE)				\$	-

ADDED BID ALTERNATE NO. 1

NONE					
N/A	MOBILIZATION, BONDS & INSURANCE	0	LS	\$ -	\$ -
N/A	TRAFFIC CONTROL	0	LS	\$ -	\$ -
TOTAL BID ALT. NO. 1				\$	-

TOTAL BASE BID INCLUDING ADDITIONAL BID ITEMS (TOTAL OF ITEMS IN THE COLUMNS ABOVE)				\$	-
The total bid shall be entered in the space provided above, and shall also be entered in the space provided in the Bid Summary Sheet. All construction shall be completed per the City of BURNET's Technical Construction Standard Manual. Contractor will be required to provide insurance certificate and performance bonds per the specs.				Payment for all Items shall be base on Plans Quantity , as described in <i>Measurement and Payment</i> , unless otherwise noted.	

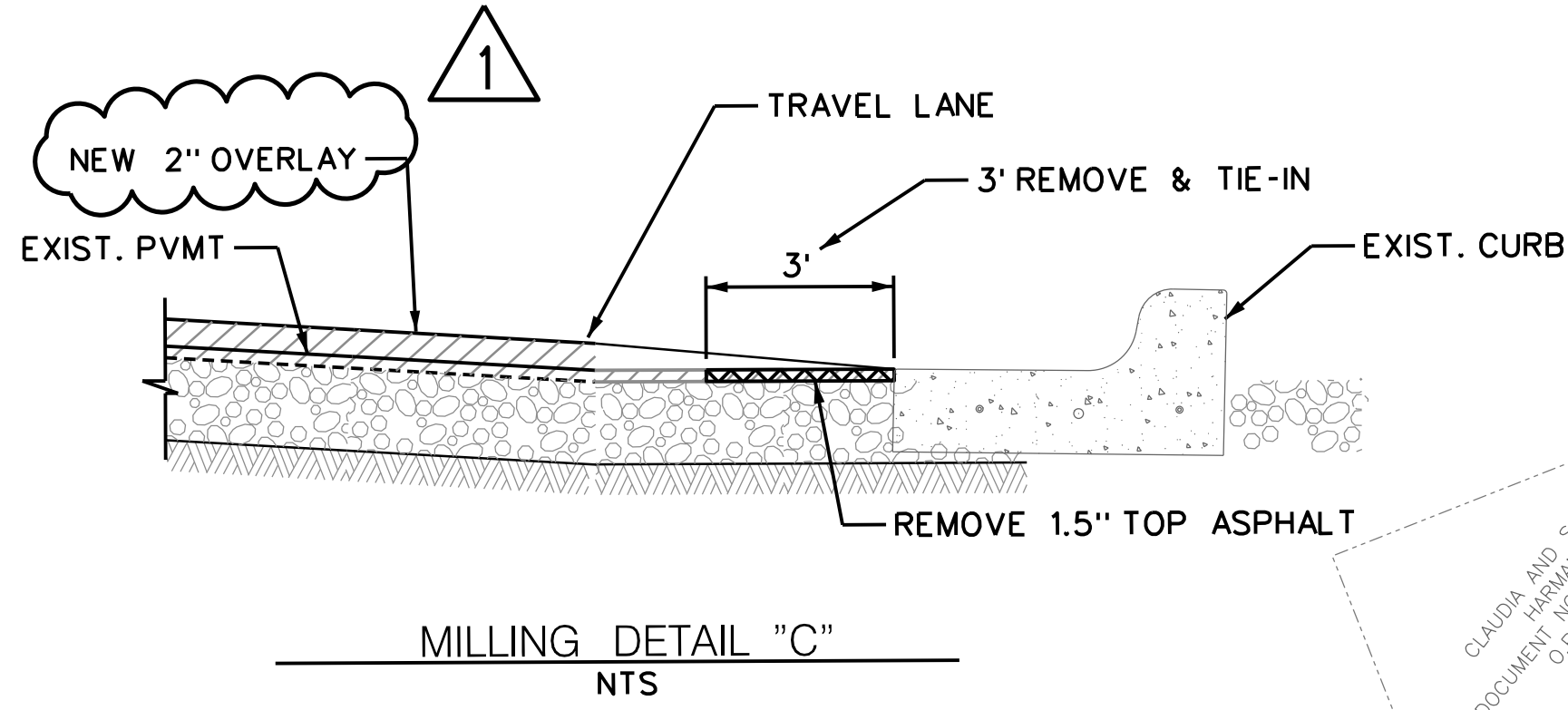
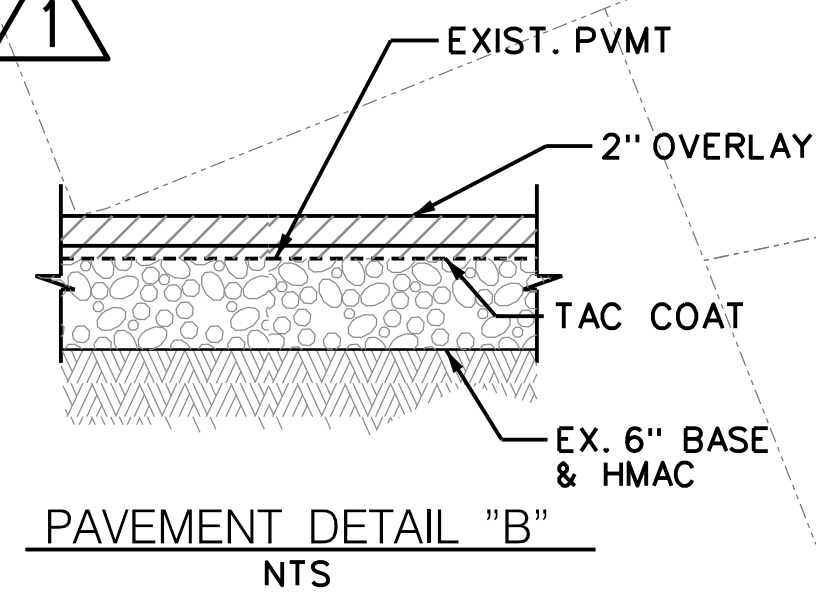
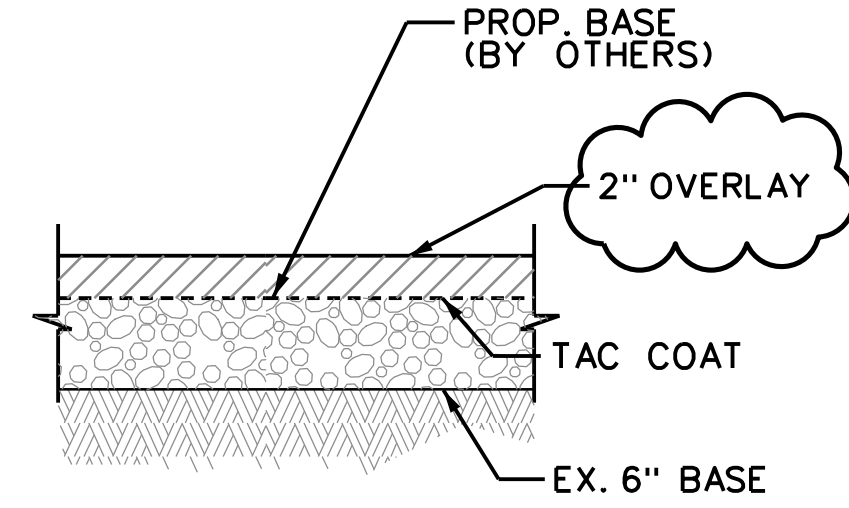

NOTES:

1. SEE ADDITIONAL NOTES ON COVER SHEET.
2. CONTRACTOR SHALL SUBMIT TO CITY MATERIAL SPECIFICATIONS FOR APPROVAL PRIOR TO CONSTRUCTION
3. PAVEMENT PREP. SHALL OCCUR ACCORDING TO SPECS. PRIOR TO CONSTRUCTION. CONTRACTOR AND CITY REPS. ARE TO WALK THE ENTIRE ROADWAY AND MARK LOCATION OF UTILITY APPURTENANCES.
4. ALL UTILITY APPURTENANCES ARE TO BE COVERED REPAIRABLY TO PREVENT PAVING OVER, AND REMOVED AFTER CONSTRUCTION. CONTRACTOR TO TAKE MEASURES TO LOCATE SUCH APPURTENANCE COVERINGS DURING AND AFTER PAVING OPERATIONS.
5. ANY AND ALL LOOSE ASPHALT AND OTHER CONSTRUCTION MATERIALS SHALL BE SWEEP AND REMOVED FROM SITE WHERE CONSTRUCTION IS OCCURRING PRIOR TO THE CONTRACTOR'S OPERATIONS LEAVE FROM THAT VICINITY.
6. CONTRACTOR SHALL PREPARE CONSTRUCTION FLYERS AND PLACE THEM AT EACH RESIDENCE FRONTING THE STREET. THE FLYER SHALL ALSO BE PRESENTED TO THE CITY FOR APPROVAL.
7. CONTRACTOR SHALL SUBMIT A TRAFFIC FLOW AND CONSTRUCTION SEQUENCING PLAN TO THE CITY FOR APPROVAL AND DISCUSSION. THE CITY ANTICIPATES ONE LANE OF TRAFFIC BEING OPEN AT ALL TIMES. SEGMENTS, WHERE NO DETOUR IS POSSIBLE THE CONTRACTOR TO PROVIDE FLAGMEN.
8. CONTRACTOR SHALL MAINTAIN TRAFFIC FLOW AT ALL TIMES, VIA FLAGMEN, GUIDE VEHICLES, CONES AND DETOUR SIGNS OR OTHER MEANS AS APPROVED BY THE CITY.
9. PAVEMENT PREPARATION, OVERLAY AND STRIPING INSTALLATION SHALL CONFORM TO THE CITY'S SPECIFICATIONS.
10. FLEXIBLE PVMT. SHALL COMPLY WITH SECTION 406.1 OF THE SPECIFICATIONS.

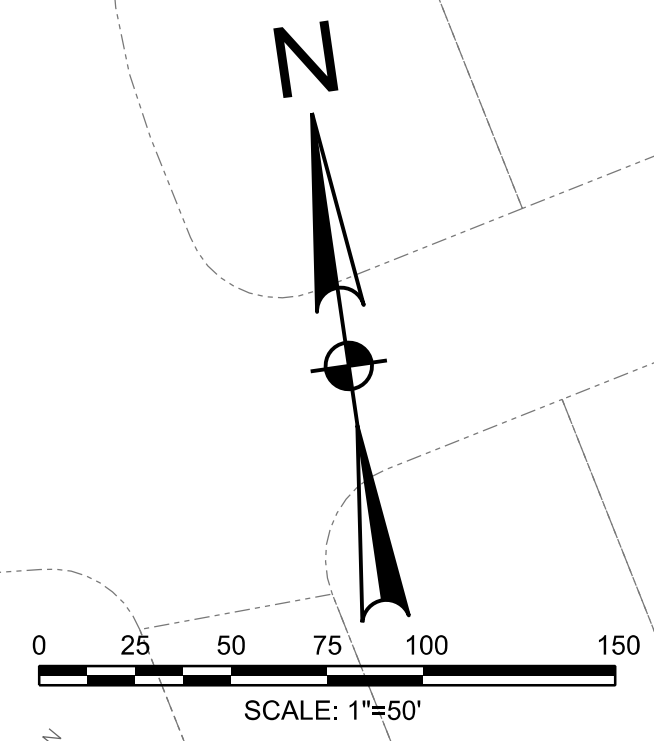

CITY OF BURNET
 1001 BUCHANAN DR. SUITE 04
 BURNET, TX 78611
 PH: (512) 756-6093



NO.	DESCRIPTION	DATE	ID
1	changed pavement thickness to 2"	4/6/2022	eb



2022 STREET REHAB PROGRAM
WOODLANDS NEIGHBORHOOD

SHEET NO.
C02